

REV	DESCRIPTION	DATE	BY
1	INITIAL RELEASE	6/27/17	TDS

1/4-28 UNF - 2B
TO BOTTOM OF HOLES
└─┘ $\varnothing.281$ (6 PLACES)

1/4-28 HOLE PATTERN

■ "A" = $\llcorner .XXX$
(2 PLACES)
CENTERED

■ "B" = $.XXX$

■ "C" = $.XXX$

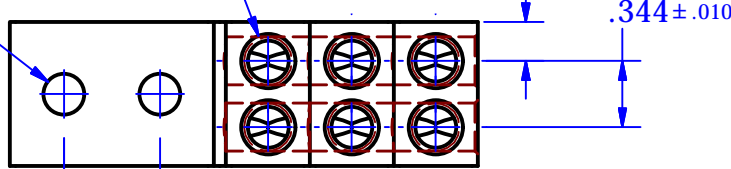

Cat No. S4-3 Style No. ALL

- Drill, Enlarge, or Modify Mounting Holes
- 1) Increase hole(s) dia. to 1/2 bolt.
- 2) Move location of mounting hole(s)
- 3) If buying blank lug, put custom hole(s) in.

IHI UL/CSA Installation Guide to Drill or Enlarge Mounting Holes:

<https://lugsdirect.com/PDF%20Documents/IHI-MTG-HOLE-FIELD-MODS-UL&CSA-CERTIFICATIONS.pdf>

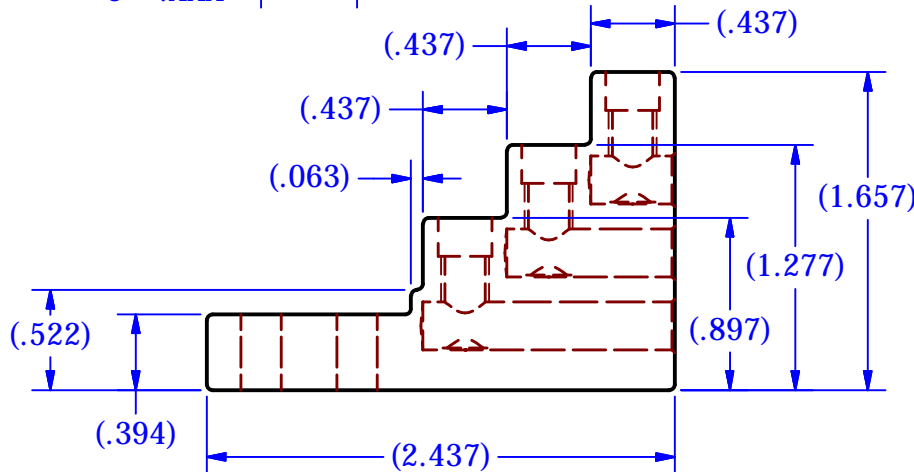
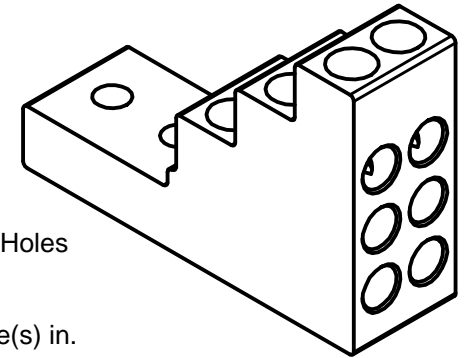

.344 ± .010
HOLE PATTERN
CENTERED
ON SAW CUT

1.094

.714

.334

.000

.750 ± .015

CHAMFER
(6 PLACES)

$\varnothing.25$

$\varnothing.25$

$\varnothing.25$

BOMS
STANDARD

- (1) 6S4-3-21-28-HEX
- (6) 13695 SCREW (1/8) HEX
CUSTOM OPTION
- (1) 6S4-3-21-28-HEX-M
- (6) 14975 SCREW (3mm)

FLEX WIRE 8-14 AWG

IHI CONNECTORS

PARTS MARKED

S4-3
IHI
UL Logo
CSA Logo
4-14 CU7AL

NOT FOR USE WHERE FAILURE CREATES A HAZARD TO HUMAN HEALTH OR SAFETY. ALL PRODUCTS ARE SUBJECT TO THIS FULL DISCLAIMER: <http://www.ihiconnectors.com/disclaimer.html>

FOR FURTHER INFORMATION ON THE PROPER USE OF THIS PRODUCT IN SPECIFIC APPLICATIONS SEE <http://www.ihiconnectors.com/GuideToFlexFlexibleFineStrandedWireCableMechanicalLugsFAQ.html>

<http://www.ihiconnectors.com/Technical-Data-Installation.htm>

THIS DRAWING AND DESIGN ARE THE PROPERTY OF INTERNATIONAL HYDRAULICS, INC., CLEVELAND, OHIO, AND MAY NOT BE DUPLICATED, USED FOR THE BASIS OF DESIGN OR MANUFACTURE WITHOUT THE WRITTEN PERMISSION OF INTERNATIONAL HYDRAULICS, INC., CLEVELAND, OHIO.

INTERNATIONAL HYDRAULICS, INC.

**GENERAL TOLERANCES
 $\pm .015$ ($\pm 0,038$)**

TITLE:
**4-14 CU7AL 85A / CU 4 AWG 6 WIRE
3 TIER STACKED COMPACT LUG
WITH TURN PREVENT DUAL BOLTS**

TABLE			
Part Number	Dia. "A"	Dim "B"	Dim "C"
6S4-3-BLANK	N/A	N/A	N/A
6S4-3-21-28	.210+.010-.005	.282	.500

MOUNTING HARDWARE ■
(2) #10 or M5 BOLTS
(2) M5 or (SAE) WASHERS

MATERIAL: XSX-3-STUB	SIZE: A	DRAWN BY: TDS	DWG NO.:	REV:
FINISH: TIN PLATE	DATE: 6/27/17	THIS IS A CAD DRAWING, DO NOT MANUALLY REVISE		